

# Renegade™ LXT40

**Find out why  
more fleets and  
owner operators  
run with  
Fontaine® than  
ever before!**

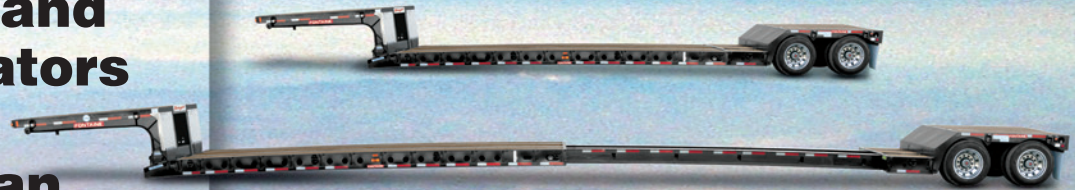

## Fontaine Renegade LXT40 Extendable Lowbed

- True 40 ton capacity in 16 feet  
(GAWR and tire ratings determine legal payloads)
- Mechanical, removable gooseneck with  
fifth wheel guide rollers
- 81" swing radius with 9' 10" overall  
gooseneck length
- Flat, level deck with 29' clear deck length  
in the closed position
- Sloped front ramp features traction cleats  
for easier loading and unloading
- Air-ride suspension with automatic and  
manual controls
- Combination figure-eight plate provides  
50" and 52" loaded fifth wheel heights  
to accommodate a wide variety of trucks

... and so much more. See your local Fontaine  
Heavy-Haul Dealer today and let's get to work!



[www.fontaineheavyhaul.com](http://www.fontaineheavyhaul.com)



# Fontaine Renegade LXT40 Lowbed Specifications

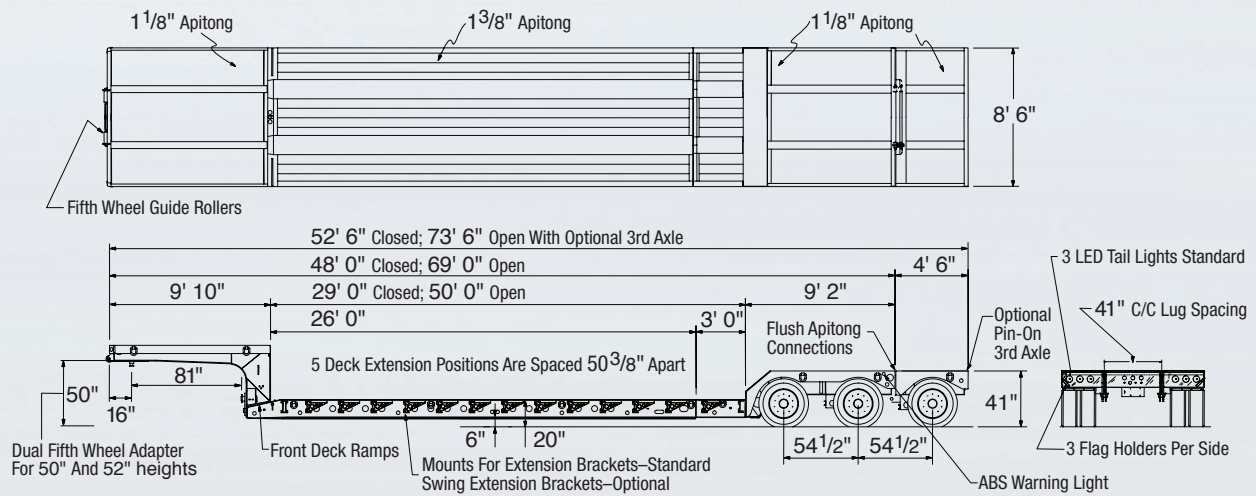

## MAIN BEAMS

- All main longitudinal members fabricated with 100 KSI minimum yield steel flanges with 50,000 lb webs

## CAPACITY

- 40 tons in 16' (GAWR and tire ratings determine legal payloads)

## LOAD BASE

- 16' rigid 2-point load centered in deck

## LOADED FIFTH WHEEL HEIGHT

- Combination figure-eight plate provides 50" and 52" loaded height to easily accommodate a wide variety of trucks

## GOOSENECK

- Mechanical removable design with fifth wheel guide rollers
- Full-width gooseneck platform for greater loading space with 1 1/8" apitong or equivalent flooring
- J560 7-pin electrical connector

## TELESCOPIC DECK DESIGN

- 20" loaded deck height with 6" ground clearance
- Front of deck is sloped and features traction cleats to make loading and unloading easier
- Full-width 1 3/8" nominal apitong or equivalent flooring
- Mounting brackets to accommodate optional extension brackets

## BOGIE DESIGN

- Covered rear bogie platform with 1 1/8" apitong or equivalent flooring
- Fixed deck-to-bogie connection with full-width bogie ramp
- Connections for future axle (including air and electrical)

## AXLES

- 2 heavy-duty axles with 54 1/2" spread
- Air/electrical connections in place for easy third axle connection
- 25,000 lbs nominal capacity per axle (GAWR determined by suspension type, brakes, tires and other components)
- Tapered spindle axles, automatic slack adjusters and spring brakes

## 2S/2M ANTILOCK BRAKE SYSTEM

- ABS wired to center pin of 7-way socket
- Electronic sensors at every wheel end
- Virtually eliminates tire flat-spotting

## BRAKES

- Spring brakes (2 axles)
- 16 1/2" x 7" with 5 1/2" autoslacks
- Heavy-duty brake drums, outboard mount
- Quick change replacement feature saves repair time
- Automatic slack adjusters maintain positive braking action

## HUBS

- Hub-piloted 10-stud mount for increased capacity and durability
- Outboard cast drums save time and cost on brake repairs

## WHEELS/TIRES

- 8.25 x 22.5 steel disc wheels with 255/70R 22.5 H-ply tires

## SUSPENSION

- Unitized air-ride suspension with automatic and manual controls
- Suspension mount is engineered, reinforced and braced to virtually eliminate frame cracking

## ELECTRICAL SYSTEM

- Sealed harness for maximum corrosion resistance
- DOT sealed beam with LED lights
- 7 marker lights per side including mid-turn signal
- 3 stop, tail and turn lights per side on rear

## PROTECTIVE COATING

- Highest quality 2-part polyurethane enamel fights corrosion to extend the life of your trailer
  - Shot blasted and cleaned prior to painting
  - Primed for better paint adhesion

## LASH RINGS

- 9 pair (18 total), bent D-Ring design ensures longer chain life and better payload securement

## FLAG HOLDERS

- 3 pair (6 total)

## ACCENT PACKAGE

- Aluminum fenders at rear of gooseneck
- Stainless steel bumper insert
- Stainless steel laser-cut Renegade logo panel

## ESTIMATED EMPTY WEIGHT W/O

OPTIONS: 20,040 lbs ± 3%

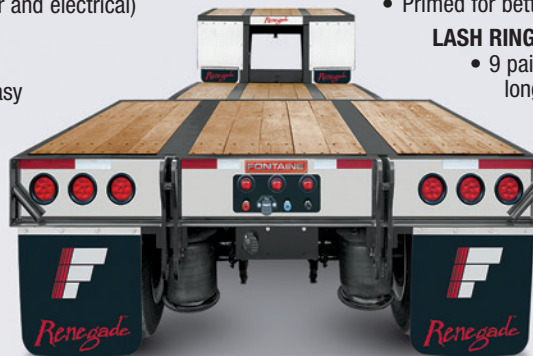

Specifications subject to change without notice.  
Photos show some optional equipment.



Fontaine Heavy-Haul • 5398 US Highway 11 • Springville, AL 35146 • 205-467-6171 • www.fontaineheavyhaul.com